

XTR Front Wheel WH-M9020-TL-F15-29 For Disc Brake

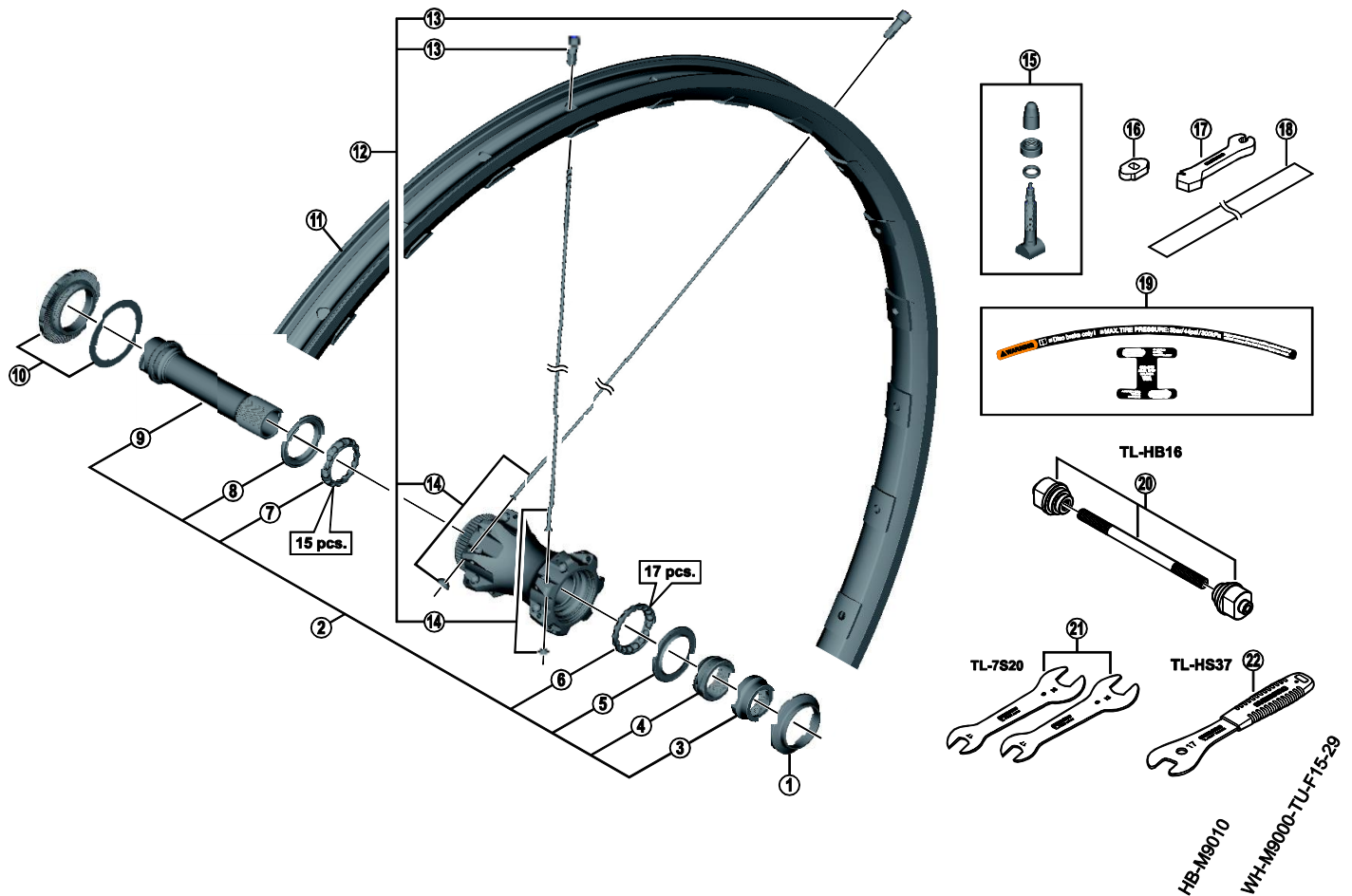

ITEM NO.	SHIMANO CODE NO.	DESCRIPTION	INTERCHANGEABILITY
1	Y27X17000	Cap	A A
2	Y47V98010	Complete Hub Axle	A A
3	Y27X19100	Right Hand Lock Nut (M19)	A A
4	Y27X11000	Right Hand Cone (M19)	A A
5	Y27X15000	Right Hand Seal Ring	A A
6	Y27X98030	Right Hand Ball Retainer (5/32" x 17)	A A
7	Y27X98040	Left Hand Ball Retainer (5/32" x 15)	A A
8	Y27X14000	Left Hand Seal Ring	A A
9	Y47V98020	Hub Axle Unit	A A
10	Y29F98010	Lock Ring & Washer	A A
11	EWHRIM2F4L	Rim {28H}	
12	EWHSPOKE272L	Spoke Unit {Spoke (298 mm x 28 pcs.) / Spherical Washer (28 pcs.) / Nipple (28 pcs.)}	
13	Y012Z4079	Nipple	A
14	Y47V98030	Spoke (298 mm) w/Spherical Washer	
15	Y4RJ98020	Valve Unit	
16	Y4RJ10000	Valve Tool	
17	Y4EF28000	Nipple Wrench 4.0	A
18	Y48F00010	Tubeless Tape	
19	Y48F98010	Rim Sticker Unit	
20	Y20W98020	TL-HB16 Hub Setting Tool	A
21	Y13098900	TL-7S20 Hub Spanners (17 mm x 22 mm) 2 pcs.	A
22	Y23098030	TL-HS37 Hub Spanner (17 mm)	A

A: Same parts.

B: Parts are usable, but differ in materials, appearance, finish, size, etc.

Absence of mark indicates non-interchangeability.

Jan.-2015-3800B

© Shimano Inc. I

Specifications are subject to change without notice.

SHIMANO