



TREK

MTB Suspension Diagram & Technical Information

2017 Top Fuel - All

Applicable Models:

2017 Top Fuel 9.9, 9.8, 9.8 WSD, 9, & 8,

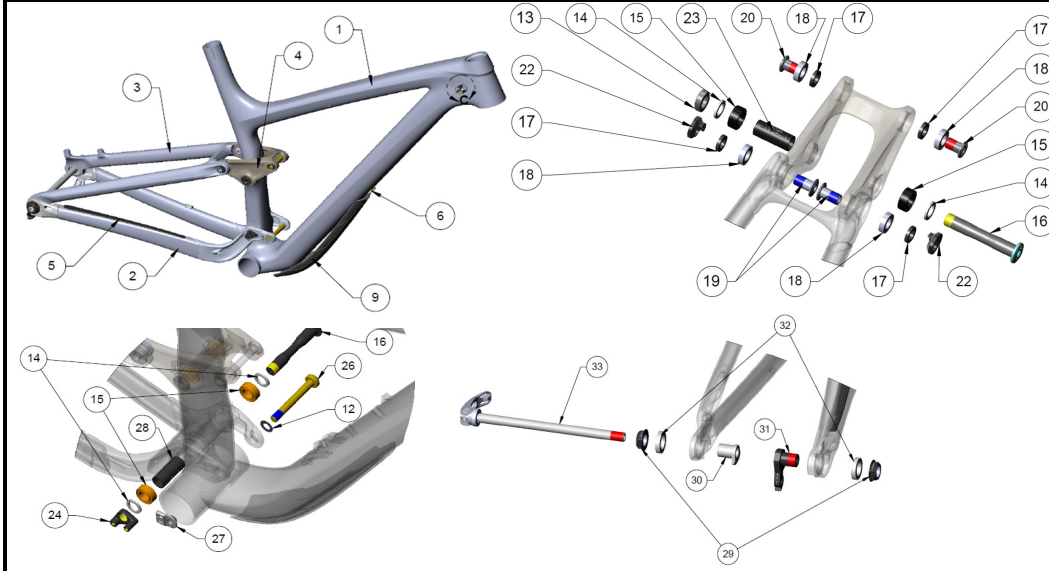

Suspension Hardware

Number	TCG Part Number	Description	Notes	Quantity Needed
1	Contact Rep for warranty and aftermarket sale info	2017 Trek Top Fuel Main Frame		1
2		2017 Trek Top Fuel Chainstay		1
3		2017 Trek Top Fuel Seatstay		1
4		2017 Trek Top Fuel Magnesium Rocker Link		1
5	W518966	Chainstay Guard - Aluminum Chainstays		1
5	W514372	Chainstay Guard - Carbon Chainstays (9.9 Only)		1
6 (See Below)	W513977	Control Freak Downtube Zip Tie Guide	See Separate Control Freak Cable Management TrekU Video	0 or 1; 1 Stock
7 (See Below)	W513980	Control Freak Headtube Cable Guide		2 or 0; 2 Stock
8 (See Below)	W519232	Control Freak Headtube Cable Plug		1 or 3; 1 Stock
9	W513305	Control Freak Downtube Guard		1
10 (See Below)	W513981	Control Freak Downtube Plug		0 or 1; 0 Stock
12	W275702	Lower Shock Bolt Washer		1
13	W311582	Top Fuel Rocker Pivot Nut		1
14	524419 or 542586	Top Fuel Pivot Spacer		4
15	W541147 or 542586	Top Fuel Pivot Bearing		4
16	524419 or 542586	Top Fuel Pivot Axle	16 Nm	2
17	W292474	Rocker Link to Seatstay Pivot Spacer		2
18	W293466	Rocker Link to Seatstay & Rocker to Shock Bearing		4
19	W509392	Rocker Link Bolt	17 Nm	2
20	W531742	Upper Shock Bolt - Re:Aktiv XC	17 Nm	2
22	W524645	Rocker Link Mino Nut 2016		2
23	524419 or 542586	Top Fuel Pivot Bearing Spacer	Same as Item 28	2
24	W509791	Top Fuel 2x Main Pivot Nut - 29er Sizes	2x Drivetrains Only	1
24	W518033	Top Fuel 2x Main Pivot Nut - 27.5 Only (15.5")	2x Drivetrains Only	1
24	W514206	Top Fuel 1x Main Pivot Nut - 29er Sizes	1x Drivetrains Only	1
24	W518034	Top Fuel 1x Main Pivot Nut - 27.5 Only (15.5")	1x Drivetrains Only	1
26	W511147	Lower Shock Bolt	10 Nm	1
27	W320302	Lower Shock Nut/Rear Derailleur Cable Guide		1
28	524419 or 542586	Top Fuel Pivot Bearing Spacer	Same as Item 23	2
29	W301803	ABP Convert Nut	22.6 Nm	2
30	W301804	ABP Non-Drive Side Axle Bolt		1
31	W301805	ABP Rear Derailleur Hanger		1
32	W305083	ABP Convert Bearing		2
Not Pictured	W306006	ABP Convert Bearing Spacer	Carbon Models	2
33	W333770	Trek Rear Axle 148x12mm 198mm Long	All 29er versions	1
33	W331114	Trek Rear Axle 142x12mm 192mm Long	27.5 15.5" Size	1

Hardware Kits

Number(s)	TCG Part Number	Description	Notes	Quantity
14-16, 23, 28	524419 or 542586	Trek Top Fuel Pivot Kit - Main and Rocker Pivots	Nut(s) Are Separate	2
29 through 32	427343	ABP Convert Kit 148x12 & 142x12	All Wheel Sizes	1

Variances from Carbon to Aluminum

- A. Control Freak Cable Routing Only on Carbon Models
 B. ABP Bearing Spacer (W306006) Needed With Carbon Seatstays

Technical Information and Specifications

Item	Description or Specification
Frame Travel	100 mm / 3.9"
Designed Fork Axle-Race	501 mm
Shock Eye to Eye and Stroke	165x38 / 6.5"x1.5" Trunion Mount Upper
Upper Shock End Width	54 mm
Upper Shock Hardware Diameter	8 mm
Lower Shock End Width	50 mm Offset 10 mm to the Non Drive Side
Lower Shock Hardware Diameter	8 mm
Available Sizes	15.5", 17.5", 18.5", 19.5", 21.5"
ISCG Tabs	NA
Max Chainrings	Small: 26T (2x) / Middle: 36T (1x) / Large: 38T (2x)
Front Derailleur Style	Low Direct Mount Side Swing Front Pull Only - Mounts to Main Pivot Nut
Rear Brake Mount	Direct Post Mount (140 mm Adaptable to 160 mm)
Wheel Size	Smart Wheel Size: 27.5 (15.5") / 29 (All Other Sizes)
Bottom Bracket	Pressfit BB92 (2.5 mm Spacer NOT Needed)
Designed Q-Factor	166 mm
Headset Style	Fully Integrated / IS with E2 Taper
Max Tire Size	29 x 2.2"
Rear Hub OLD	142x12 (Size 15.5") / 148x12 (All Other Sizes)
Rear Axle Length	192 mm (Size 15.5") / 198 mm (All Other Sizes)
Seatpost OD	31.6 mm
Seat Collar ID	36.4 mm
Derailleur Hanger	W301805
Internal Cable Routing Options	Alloy: Front Derailleur, Rear Derailleur, Stealth Dropper Post Carbon: Front Derailleur, Rear Derailleur, Stealth Dropper Post, Rear Brake Line, Shock Lockout

Cable Routing Diagram - Alloy

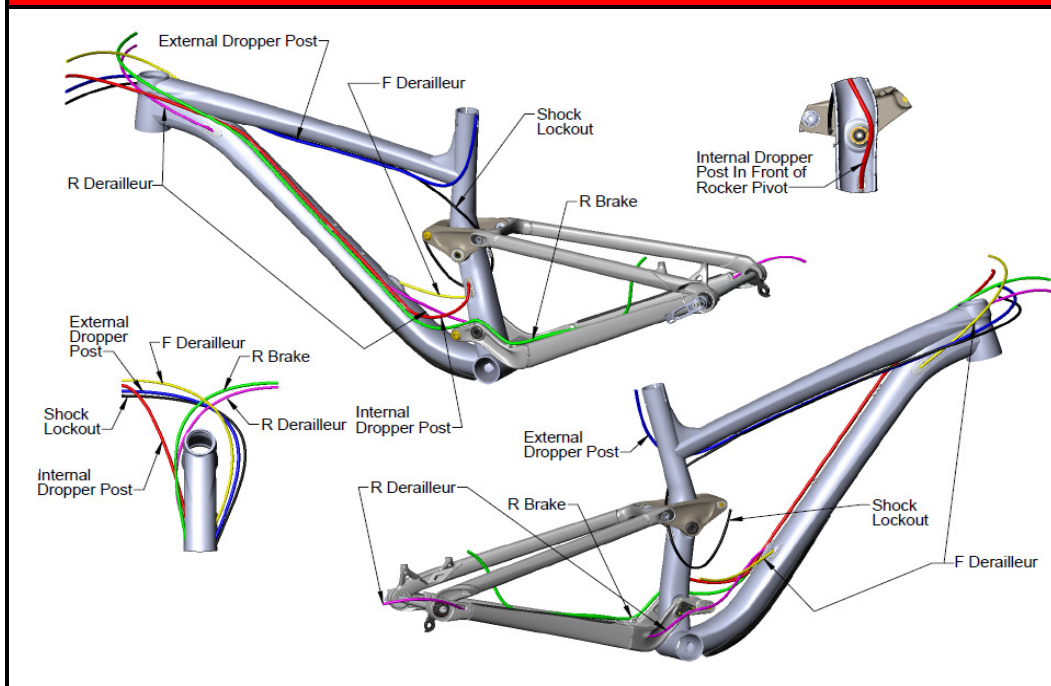

Top Fuel Aluminum - Cable Specific Hardware

TCG Part Number	Description	Quantity Needed
W439610	Downtube Cable Exit Stop - Requires W321538	1 for 1x; 2 for 2x
W318529	Downtube Cable Exit Stop Hardware	1 or 2, match to W439610
W320324	Headtube Cable Entry Plug	0 for 2x; 1 for 1x
W329840	Downtube Cable Exit Plug	0 for 2x; 1 for 1x
W509791	Top Fuel Low Direct Front Derailleur Mount Main Pivot Nut	0 for 1x; 1 for 2x
W514206	Top Fuel 1x Main Pivot Nut	0 for 2x; 1 for 1x
W320511	Stealth Dropper Port Plug	0 for Stealth Droppers; 1 for Rigid or Ext. Dropper
W321543	Zip Tie Anti-Wear Sleeve	Optional, 1 per zip tie mount used

Cable Routing Diagram - Carbon

See Also: Trek U Video on Control Freak Cable Management

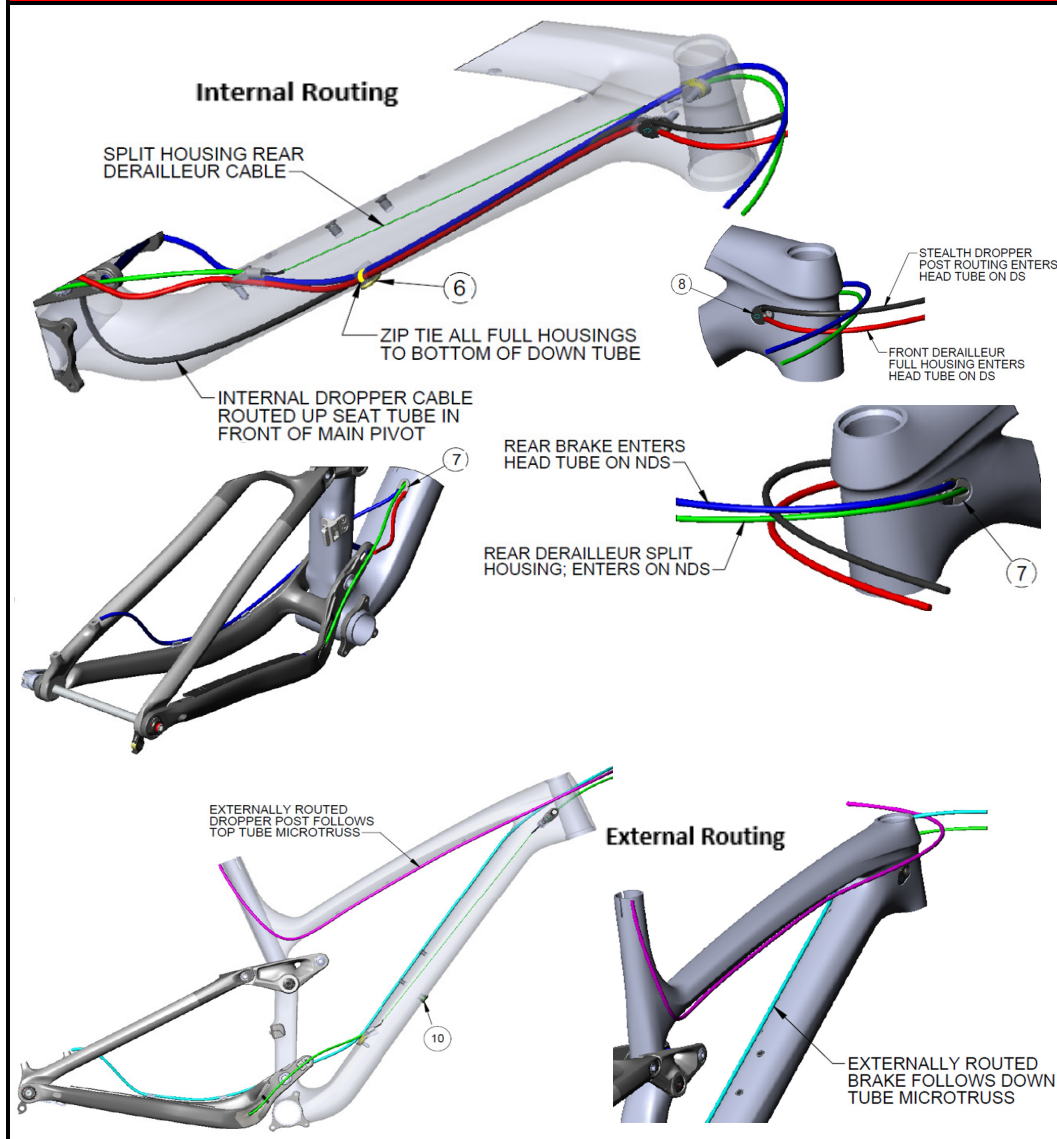

Top Fuel Carbon - Cable Specific Hardware

Number	TCG Part Number	Description	Notes	Quantity Needed
6	W513977	Control Freak Downtube Zip Tie Guide	See Separate Control Freak Cable Management TrekU Video	0 or 1; 1 Stock
7	W513980	Control Freak Headtube Cable Guide		2 or 0; 2 Stock
8	W519232	Control Freak Headtube Cable Plug		1 or 3; 1 Stock
9 (See Above)	W513305	Control Freak Downtube Guard		1
10	W513981	Control Freak Downtube Plug		0 or 1; 0 Stock
Not Pictured	W439072	Control Freak Fixing Hardware		3
Not Pictured	W321543	Zip Tie Anti-Wear Sleeve		Optional, 1 per zip tie mount used